



TVIHD8VD-21M-W

8MP OUTDOOR IR DAY/NIGHT
VANDAL DOME HD-TVI CAMERA

FEATURES

- 15FPS @ 8MP (3840 x 2160)
- 2.7~13.5mm Motorized Auto-focus Lens
- HD-TVI / HD-CVI / AHD / Analog Video Output
- IR Range up to 200'
- DWDR, DNR, Day/Night
- Outdoor IP67, Vandal-proof
- 12VDC / 24VDC
- Available in White

Rainvision is a leading brand of HD and IP network video surveillance cameras and recording equipment. By utilizing the latest technology in the industry, Rainvision video surveillance cameras provide all of the crisp, clear image quality in any security application or environment. With incorporating the latest ONVIF Profile S standards, Rainvision allows for easy integration and interoperability.

SPECIFICATIONS

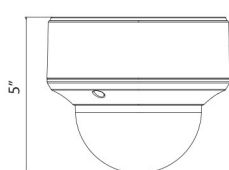
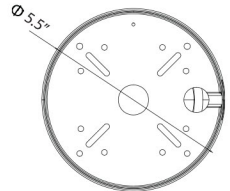
CAMERA		GENERAL	
Image Sensor	8.29 MP CMOS Image Sensor	Operating Conditions	-40 °F ~ 140 °F
Min. Illumination	Color: 0.01 Lux @ (F1.2, AGC ON), 0 Lux with IR	Power Requirement	Humidity 90% or Less (Non-condensing)
Shutter Speed	PAL: 1/12.5s to 1/50,000s NTSC: 1/15s to 1/50,000s	Power Consumption	12 VDC / 24 VAC
Lens	2.7~13.5mm Motorized Auto-focus Lens	Ingress Protection	Max. 8.2W
Day & Night	IR Cut Filter	Dimensions	IP67
IR Range	200'	Weight	Ø 5.5" x 5.0"
DNR	Supported	Warranty	1.41 lbs
DWDR	105 dB	Package Contents	3 Years
3-axis Adjustment	Pan: 0°~340°, Tilt: 0°~75°, Rotate: 0°~355°		Camera, Installation Manual/Template, Installation Accessories
Horizontal Field of View	108.1°~45.6°		
Synchronization	Internal Synchronization		
Communication	Up the Coax, HD-TVI Output		
IMAGE			
Max. Resolution	3840 x 2160		
Frame Rate	HD-TVI: 15FPS @ 8MP, 12.5FPS @ 8MP, 20FPS @ 5MP, 30FPS @ 4MP, 25FPS @ 4MP, 30FPS @ 2MP, 25FPS @ 2MP, HD-CVI: 15FPS @ 8MP, 12.5FPS @ 8MP AHD: 20FPS @ 5MP, CVBS: 960H		
IMAGE SETTING	Brightness, Sharpness, DNR, Mirror, Smart IR		
BLC	Support		
AGC	Support		
D/N Mode	Auto / Color / Black and White		
White Balance	Auto / Manual		
		 	<p>Camera base has multiple screw holes so the camera can be mounted to standard size electrical boxes.</p>