



TVIHD5VD-3-W

5MP OUTDOOR IR DWDR DAY/NIGHT
VANDAL DOME HD-TVI CAMERA



FEATURES

- 5MP (2560 x 1944) Resolution
- 2.8mm Fixed Lens
- HD-TVI / HD-CVI / AHD / Analog Video Output
- IR Range up to 65'
- DWDR, DNR, Day/Night
- Outdoor IP67, Vandal-proof IK10
- 12VDC
- Available in White

Rainvision is a leading brand of HD and IP network video surveillance cameras and recording equipment. By utilizing the latest technology in the industry, Rainvision video surveillance cameras provide all of the crisp, clear image quality in any security application or environment. With incorporating the latest ONVIF Profile S standards, Rainvision allows for easy integration and interoperability.

SPECIFICATIONS

CAMERA		GENERAL	
Image Sensor	5MP CMOS Image Sensor	Operating Conditions	-40 °F ~ 140 °F
Min. Illumination	Color: 0.01 Lux @ (F1.2, AGC ON), 0 Lux with IR	Power Requirement	Humidity 90% or Less (Non-condensing)
Shutter Speed	PAL: 1/25s to 1/50,000s NTSC: 1/30s to 1/50,000s	Power Consumption	12 VDC ±25%
Lens	2.8mm Fixed Lens	Ingress Protection	Max. 4.3W
Day & Night	IR Cut Filter	Dimensions	IP67, IK10
IR Range	65'	Weight	Ø 4.4" x 3.2"
DNR	2D DNR	Warranty	.77 lbs
DWDR	Supported	Package Contents	3 Years
3-axis Adjustment	Pan: 0°~355°, Tilt: 0°~75°, Rotate: 0°~355°		Camera, Installation Manual/Template, Installation Accessories
Horizontal Field of View	85.5°		
Synchronization	Internal Synchronization		
Communication	Up the Coax, HD-TVI Output		

IMAGE	
Max. Resolution	2560 x 1944
Frame Rate	PAL: 20FPS@ 5MP, 25FPS @ 4MP, 25FPS @ 1080p, NTSC: 20FPS @ 5MP, 30FPS @ 4MP, 30FPS @ 1080p
Image Settings	Brightness, Sharpness, DNR, Mirror, Smart IR Support
BLC	Support
AGC	Support
D/N Mode	Auto / Color / Black and White
White Balance	ATW / MWB

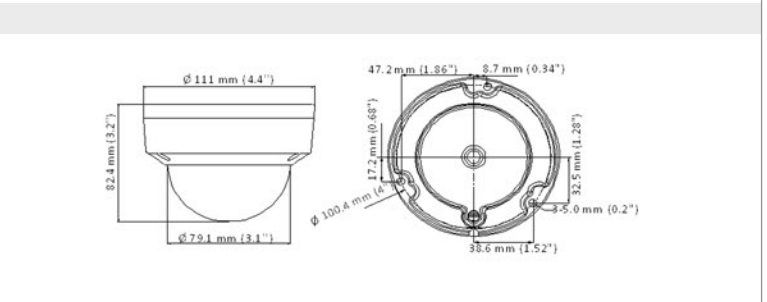

ACCESSORIES			
Junction Box JB250	Wall Mount WM210	Wall Mount WM215	Wall Mount WM215BB with Back Box
Pole Mount POLEMT5			

